

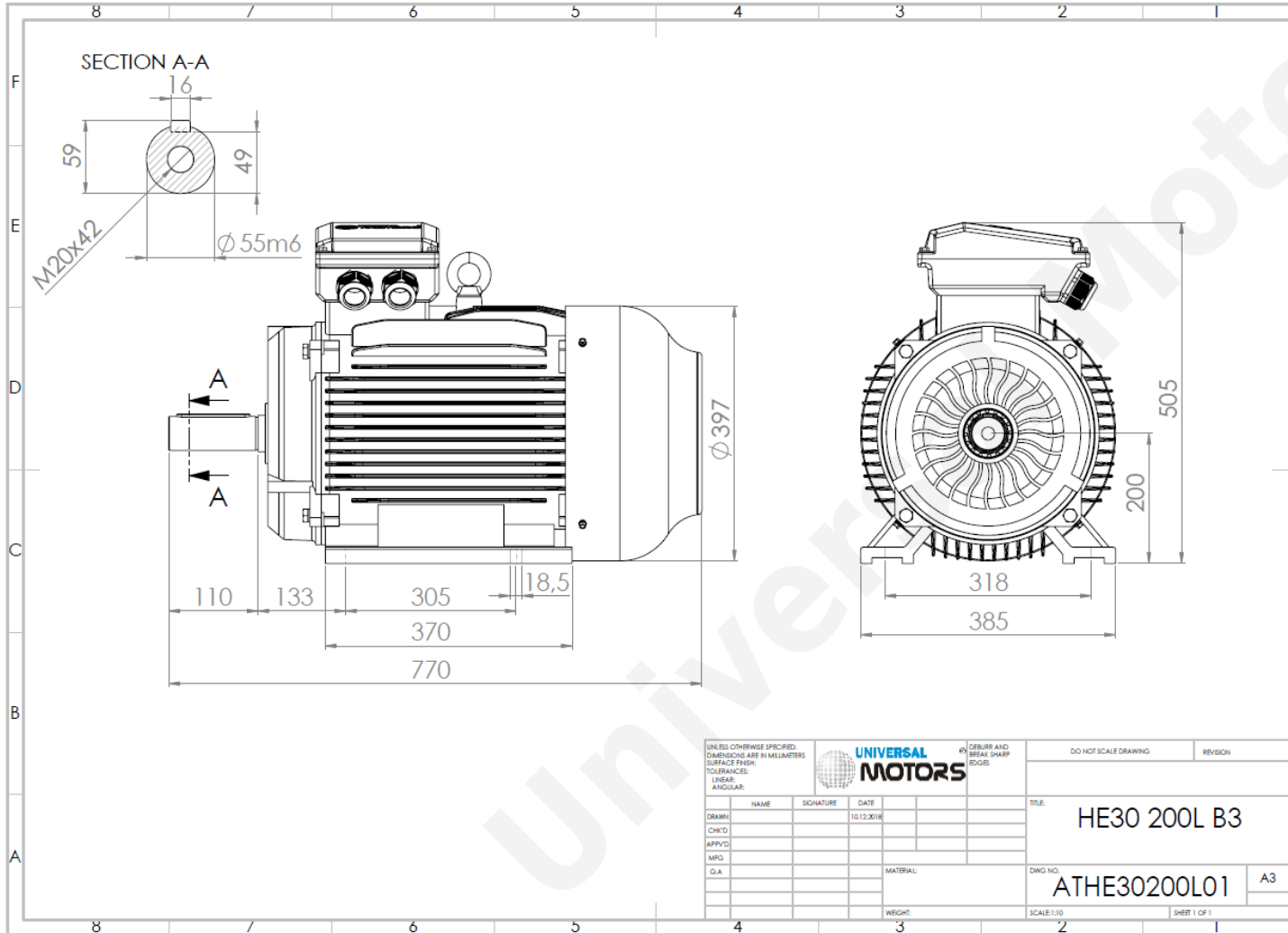

# TECHNICAL DATA

Three Phase Electric Motors - Cast Iron Frame  
 HE30 200 L-4 IE2  
 30 kW / 40 Cv  
 1470 RPM



Motor type:	<b>HE30 200 L-4 IE2</b>
Output:	<b>30 kW / 40 Cv</b>
Speed (min <sup>-1</sup> ):	<b>1470 RPM</b>
Frequency:	<b>50 Hz</b>
Voltage:	<b>400 V</b>
Current:	<b>54.6 A</b>
Power factor (Cos Ø):	<b>0.86</b>
Poles:	<b>4</b>
Insulation class:	<b>F</b>
Temperature rise Class:	<b>B</b>
Efficiency 50%:	<b>90.0 %</b>
Efficiency 75%:	<b>92.7 %</b>
Efficiency 100%:	<b>92.3 %</b>
Torque:	<b>195 N.m</b>
Tstarting/Tnominal:	<b>2.2</b>
Istarting/Inominal:	<b>7.5</b>
Tmaximum/Tnominal:	<b>2.3</b>
Noise:	<b>65 Db(A)</b>
Weight:	<b>265 Kg</b>
Bearing DE:	<b>6312 C3</b>
Bearing NDE:	<b>6312 C3</b>

Regime - S1

Altitude - 1000m

Environment Temperature - 40°C

## CONTACTS:

UNIVERSAL MOTORS Tel: +351 252 299 080  
 Rua de São Brás,745 Fax: +351 252 299 089  
 4480-782 VILA DO CONDE Mail: [geral@universalmotors.pt](mailto:geral@universalmotors.pt)

\* References applied only in the UK